



# Bi-directional Switch

## Cat XLP919WEWE & XLP920WEWE

### Instruction Manual

#### 1 Specifications

Cat No	XLP919WEWE	XLP920WEWE
Voltage rating	250V a.c.	250V a.c.
Current rating	6A	6AX
Terminal capacity	2 x 2.5mm <sup>2</sup>	
IP rating	IP41	
Storage temperature	-10°C to +70°C	
Operating temperature	-5°C to +50°C	
Resistant to the following agents	Hexane, methylated spirits, soapy water, diluted ammonia, diluted pure bleach (10%), glass cleaning substance, pre-impregnated wipes	
Not resistant to the following agents	Acetone, tar remover, trichloroethylene	

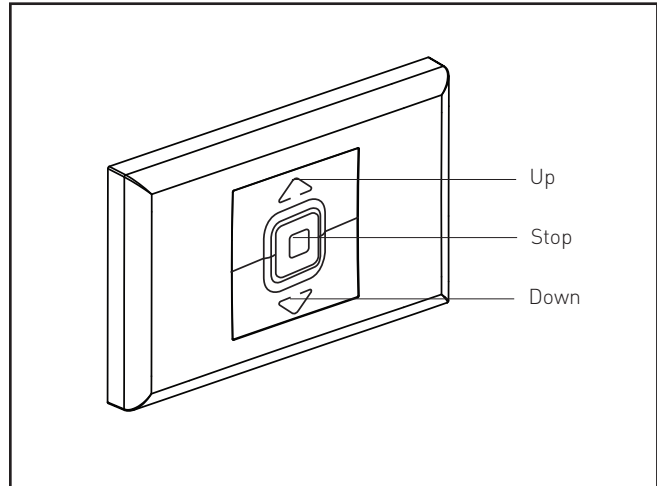

#### 2 Operation

XLP919WEWE and XLP920WEWE are three-position switches which allow bi-directional control of shutters, blinds, screens, garage doors and similar devices.

XLP919WEWE has momentary push buttons for Up, Down and Stop and so would generally be used if the device to be opened/closed has its own controller.

XLP920WEWE has latching push buttons for Up and Down, which are released by pressing Stop. This model can be wired directly to the device being controlled.

#### 3 Mechanism Dimensions

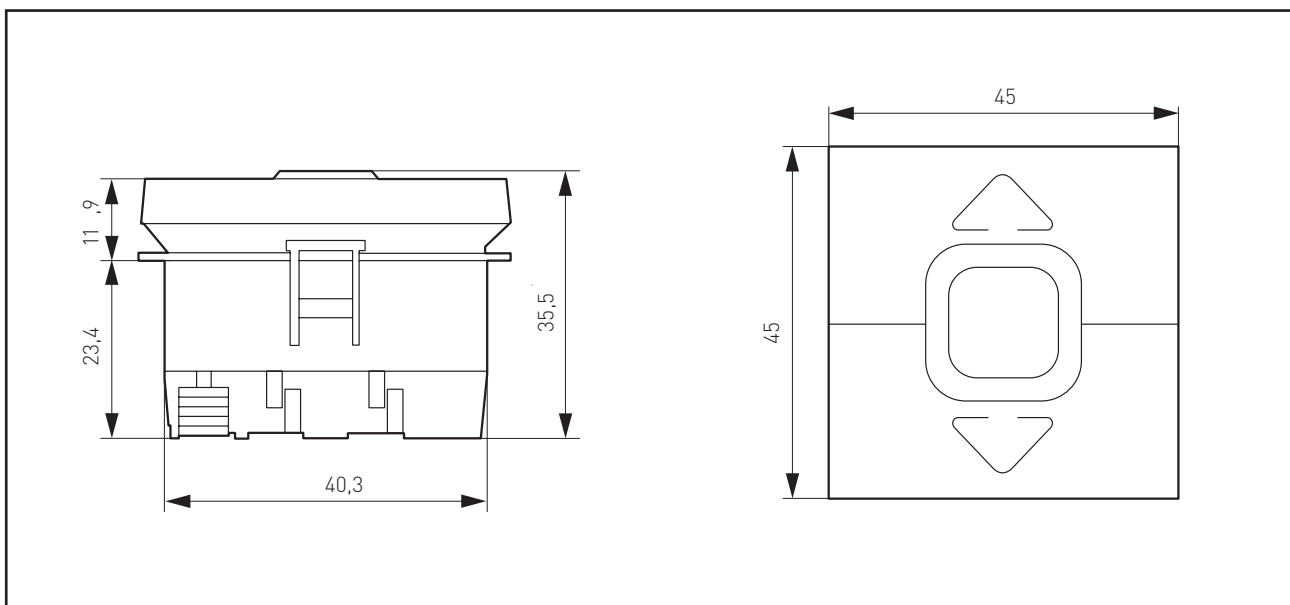

## 4 Wiring

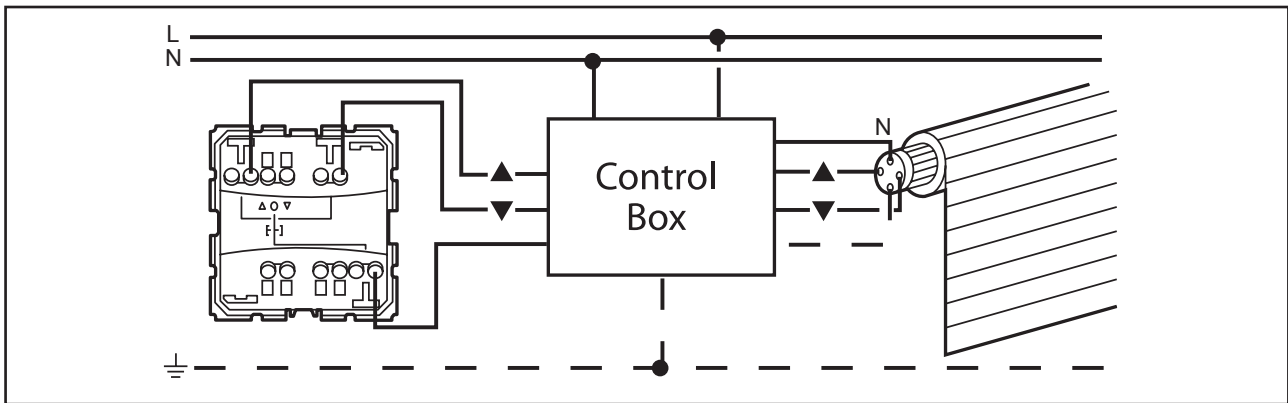

Cat XLP919WEWE wiring

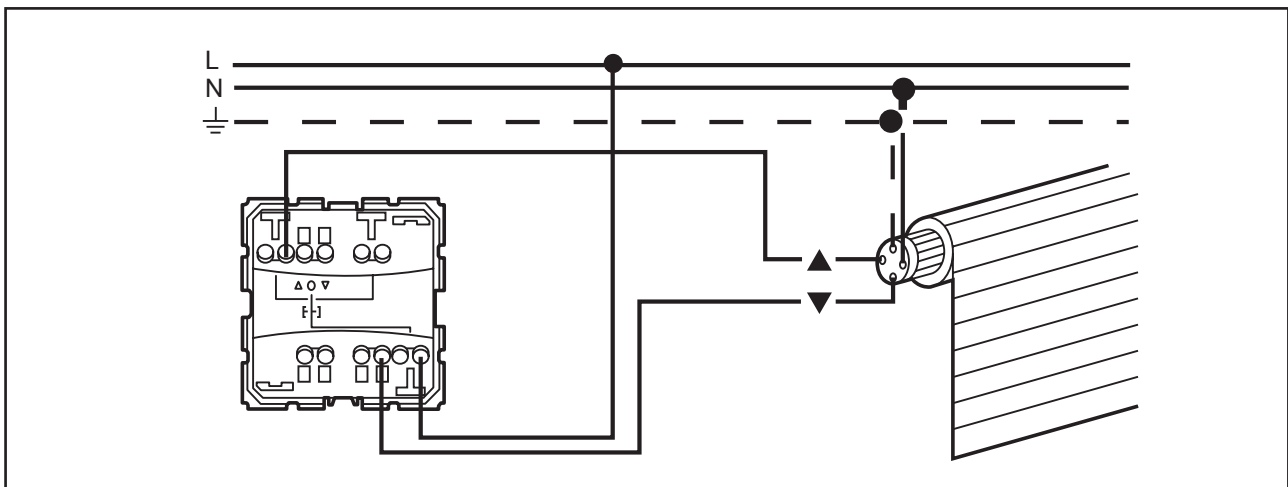

Cat XLP920WEWE wiring

## 5 Warning

These products must only be connected to the mains supply by a qualified electrician.

### Warranty

HPM Cat XLP919WEWE & XLP920WEWE are warranted as here and after appears, against faulty material and/or workmanship for a period of one year from the day of purchase. The obligation of the manufacturer under this warranty is limited to servicing and replacing defective parts when the unit is returned to the authorised place of purchase. To obtain warranty repair, the purchase receipt should be returned with the product. This warranty becomes void on any unit which has been tampered with or damaged by accident, short circuited, loaded beyond rating or damaged otherwise by improper operation. The warranty is also conditional on the unit being installed by a licensed electrical contractor. All other warranties, whether expressed or implied, and whether arising by operation of law or otherwise are hereby excluded.

### Customer Service

For all customer service and technical support please call Monday to Friday during business hours.

HPM Legrand Australia  
1300 369 777  
[www.hpm.com.au](http://www.hpm.com.au)

HPM Legrand - New Zealand  
0800 476 009  
[www.hpm.co.nz](http://www.hpm.co.nz)

Legrand Australia Pty Ltd  
ABN: 31 000 102 661

A Group Brand |  **legrand**<sup>®</sup>